

# Preliminary

## LL-U18V1C-008

### DATA SHEET



QC: 王士光

ENG: 劉為中

Prepared By: 楊銀花

Part No.	LL-U18V1C-008	Spec No.	S/N-06090503	Page	1 of 4
----------	---------------	----------	--------------	------	--------

## Package Dimensions:

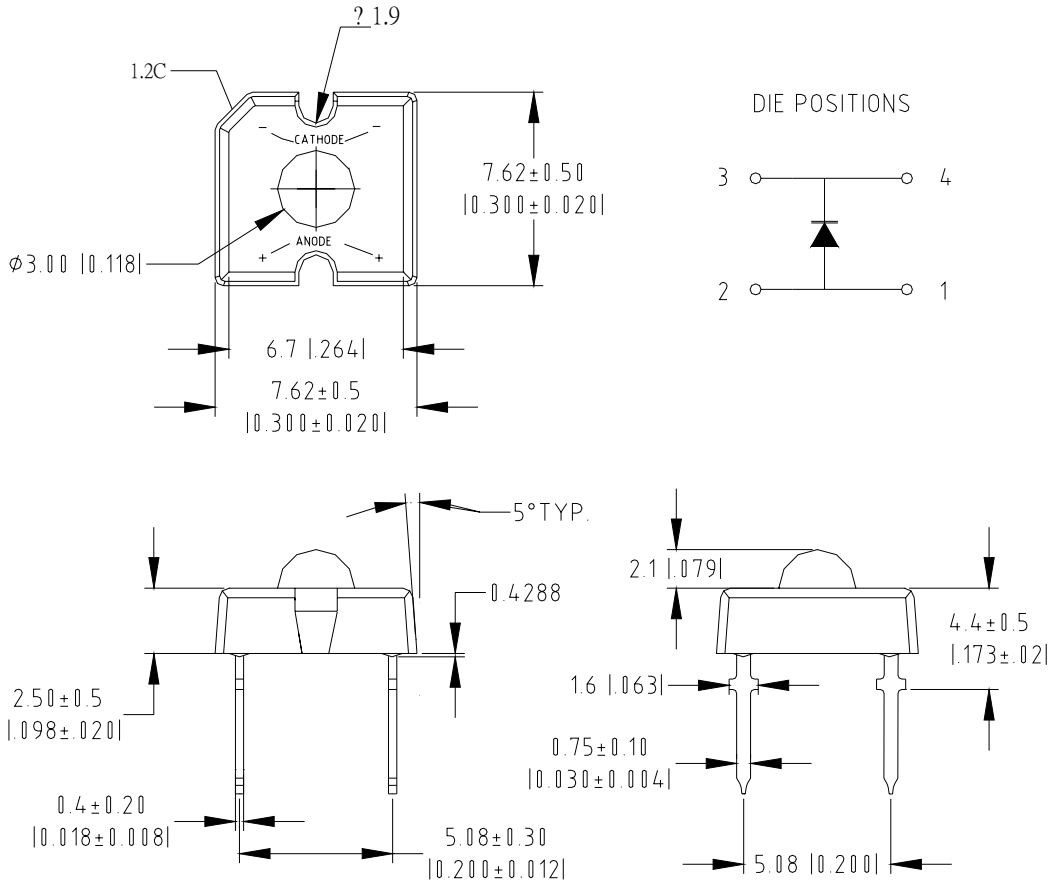

Part NO.	Chip Material	Lens Color	Emission Color
LL-U18V1C-008	InGaN	Water Clear	Super Bright Red

### Notes:

- All dimensions are in millimeters (inches).
- Tolerance is  $\pm 0.25$ mm ( $.010$ " ) unless otherwise noted.
- Protruded resin under flange is 1.0mm ( $.04$ " ) max.
- Lead spacing is measured where the leads emerge from the package.
- Specifications are subject to change without notice.
- Precautions for ESD:  
Static electricity and surge can damages the LED. It is recommended to use a wrist band or anti-electrostatic glove when handling the LED. All devices, equipment and machinery must be properly grounded.
- This data-sheet only valid for six months.



**Absolute Maximum Ratings at Ta=25°C**

Parameter	MAX.	Unit
Power Dissipation	95	mW
Peak Forward Current (1/10 Duty Cycle, 0.1ms Pulse Width)	100	mA
Continuous Forward Current	35	mA
Derating Linear From 50°C	0.4	mA/°C
Reverse Voltage	5	V
Electrostatic Discharge (ESD)	150	V
Operating Temperature Range	-20°C to +80°C	
Storage Temperature Range	-30°C to +100°C	
Lead Soldering Temperature [4mm(.157") From Body]	260°C for 5 Seconds	

**Electrical Optical Characteristics at Ta=25°C**

Parameter	Symbol	Min.	Typ.	Max.	Unit	Test Condition
Luminous Intensity	$I_v$	2200	4900		mcd	$I_f=20\text{mA}$ (Note 1)
Viewing Angle	$2\theta_{1/2}$	30	35	40	Deg	(Note 2)
Peak Emission Wavelength	$\lambda_p$	630	635	640	Nm	$I_f=20\text{mA}$
Dominant Wavelength	$\lambda_d$	620	625	630	Nm	$I_f=20\text{mA}$ (Note 3)
Spectral Line Half-Width	$\Delta\lambda$	18	23	28	Nm	$I_f=20\text{mA}$
Forward Voltage	$V_f$	1.9	2.2	2.7	V	$I_f=20\text{mA}$
Reverse Current	$I_R$			50	$\mu\text{A}$	$V_R=5\text{V}$

**Notes:**

- Luminous intensity is measured with a light sensor and filter combination that approximates the CIE eye-response curve.
- $\theta_{1/2}$  is the off-axis angle at which the luminous intensity is half the axial luminous intensity.
- The dominant wavelength ( $\lambda_d$ ) is derived from the CIE chromaticity diagram and represents the single wavelength which defines the color of the device.
- Forward voltage measurement allowance is  $\pm 0.1\text{V}$
- Luminous Intensity Measurement Allowance is  $\pm 10\%$



**Typical Electrical / Optical Characteristics Curves**  
 (25°C Ambient Temperature Unless Otherwise Noted)

**Spectral Radiance (Peak @ 635nm)**

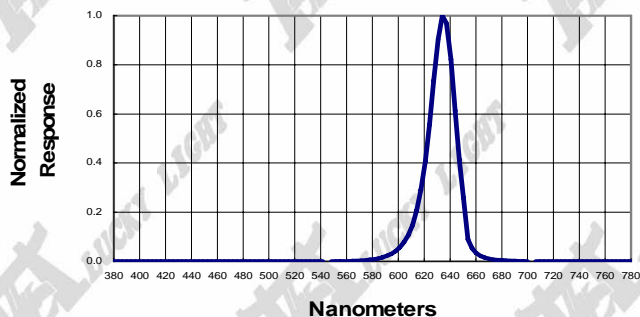

**Forward Current vs Forward Voltage**

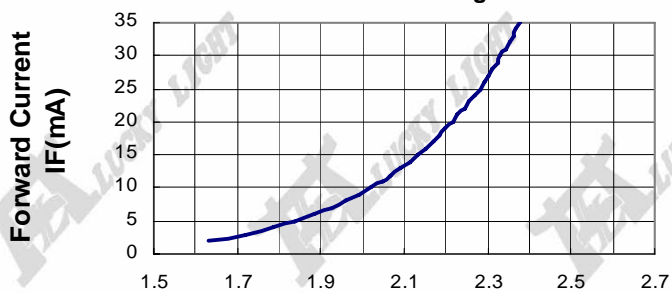

**Relative Luminous Intensity vs Forward Current**

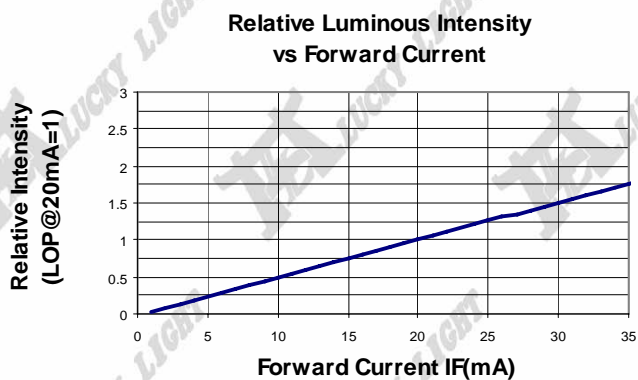

**Beam Pattern**

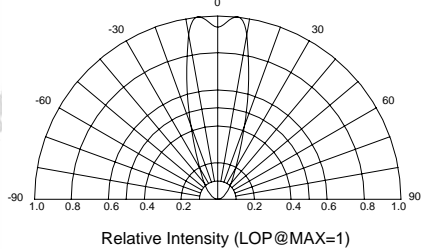

**Forward Current Derating Curve**

